

ARTICLE 19

OFF-STREET PARKING AND LOADING STANDARDS

Sec. 19.01 Purpose

The purpose of this Article is to ensure adequate and well designed parking and loading areas are provided in all districts at the time of erection, enlargement or change in use, of any principal building or lot. Off-street parking and loading areas are to be designed, maintained and operated in a manner that will ensure their efficient use, promote public safety, improve aesthetics and, where appropriate, protect surrounding uses from undesirable impacts. Off-street parking spaces, in conjunction with all land or building uses, shall be provided prior to the issuance of a certificate of occupancy as hereinafter prescribed.

Sec. 19.02 General Requirements

a. Residential Parking

1. Single-family residential off-street parking spaces shall consist of a parking strip, driveway, garage, or combination thereof, and shall be located on the premises they are intended to serve.
2. No parking shall be permitted in required yards on a regular basis on lawns or other unpaved areas on residential lots.
3. A minimum three (3) feet wide lawn or landscape strip shall be required between the edge of parking area pavement and all property lines to provide adequate room for drainage, snow storage and privacy screening.
4. Commercial and recreational vehicle parking in residential districts shall comply with the standards in *ARTICLE 2 GENERAL PROVISIONS*.
5. Garage doors facing the front yard shall be setback twenty (20) feet from the road right-of-way.

b. Location

1. Except within the CBD, off-street parking for multiple-family and nonresidential uses shall be either on the same lot or within lots under the same ownership and control within three hundred (300) feet of the building it is intended to serve, measured from the nearest point of the building or use entrance to the nearest point of the off-street parking lot, except as otherwise permitted in this chapter.
2. Within the CBD, off-street parking shall be either on the same lot, lot(s) under the same ownership and control, open public parking lots, or on the street within five hundred (500) feet of the building it is intended to serve, measured from the nearest point of the building entrance to the nearest point of the off-street parking lot. The Planning Commission may, however, require that some or all of the parking required by *Section 19.04 Parking Space Numerical Requirements* be provided outside of municipal parking lots or on-street if it is determined that sufficient capacity is unavailable within the municipal parking lot(s) or on-street. The Planning Commission can require a parking supply and demand study if necessary to make this determination.

c. Change in Use or Intensity

1. Whenever the use of a building or lot is changed, parking facilities shall be provided as required by this article for the new use.
2. If any building, structure, or lot is increased through the addition of dwelling units, increase in floor area, increase in seating capacity, or through other means, additional off-street parking

- shall be provided to bring the site into compliance.
3. Any area once designated as required off-street parking shall not be changed to any other use unless and until equal facilities meeting the standards of this article are provided elsewhere, or the parking requirements of the site change as determined by the Building Official/Zoning Administrator.

d. **Storage and Repair**

The use of required parking and loading areas for the material storage, refuse storage stations/dumpsters, storage or display of vehicles and/or merchandise, or for vehicle or machinery repair or maintenance is expressly prohibited.

e. **Control of Off-Site Parking**

It shall be unlawful to park or store any motor vehicle on private property without the expressed or implied consent of the owner, holder, occupant, lessee, agent, or trustee of such property.

f. **Collective Parking**

The collective provision of off-street parking for two (2) or more buildings or uses is permitted subject to the following:

1. The total number of spaces provided collectively shall not be less than the sum of spaces required for each separate use. However, the Planning Commission may reduce the total number of spaces by up to twenty-five percent (25%) if they determine that the operating hours of the buildings or uses do not overlap.
2. Each use served by collective off-street parking shall have direct access to the parking without crossing any public rights-of-way.
3. Written easements which provide for continued use and maintenance of the parking shall be submitted to the city for approval. Such agreement shall include provisions to address any changes in use which shall be reviewed in accordance with *Section 19.02 paragraph c. Change in Use or Intensity*.

g. **Parking Lot Deferment**

1. Where the property owner can demonstrate that the required amount of parking is excessive, the Planning Commission may approve a smaller parking area, provided that area of sufficient size to meet the parking space requirements of this article is retained as open space, and the owner agrees in writing to construct the additional parking based on observed usage within six (6) months of being informed of such request in writing by the Building Official/Zoning Administrator.
2. The site plan shall note the area where parking is being deferred, including dimensions and dotted parking lot layout.
3. Stormwater calculations shall be provided based on the required amount of parking to verify adequate capacity if an expansion is necessary.

h. **Additional Parking**

To minimize excessive areas of pavement which depreciate aesthetic standards and contribute to high rates of stormwater runoff, the number of spaces provided shall not exceed ten percent (10%) beyond the number required by this Article, except as approved by the Planning Commission. In granting such additional space, the Planning Commission shall determine that such parking will be required, based on documented evidence of actual use and demand provided by the applicant.

i. **Construction**

During construction, off-street parking shall be provided on-site for all construction vehicles and employees. Gravel surfacing may be permitted by the Building Official/Zoning Administrator for such temporary parking.

j. **Carports and Garages**

Carports and garages for multiple-family dwellings and other non-single family residential uses shall be calculated as parking spaces on a one-to-one (1:1) basis. Carports and garages in such developments shall have a maximum height of fourteen (14) feet, measured from the grade to the peak of the structure. Carports shall be enclosed or obscured at least twenty-five percent (25%) along sides visible from public streets, residential districts or vehicular drives within the site. All details must be provided on the site plan and reviewed and approved by the Planning Commission.

k. **Stacking Space Requirements**

1. Stacking spaces, as required by *Section 19.04 Parking Space Numerical Requirements*, which block access to parking spaces shall not be included in calculating the required number of spaces.
2. Each required stacking space shall be a minimum of twenty-four (24) feet long and nine (9) feet wide.
3. Stacking space shall be designed so that an efficient circulation pattern is maintained on the site and a sufficient width is available to allow a vehicle to maneuver around another vehicle waiting in line.

l. **Uses Not Cited**

For uses not specifically listed in *Section 19.04 Parking Space Numerical Requirements*, the requirements for off-street parking facilities shall be in accordance with a similar use as determined by the Building Official/Zoning Administrator or based on documentation regarding the specific parking needs for the particular use, as determined by the Planning Commission.

Sec. 19.03 Parking Units of Measurement

The following standards shall be used in determining the required number of parking spaces:

a. **Floor Area**

1. Where floor area is the unit for determining the required number of off-street parking and loading spaces, such unit shall mean the gross floor area (GFA), unless otherwise noted.
2. Where the floor area measurement is specified as gross leasable floor area (GLA), parking requirements shall apply to all internal building areas excluding the floor area used for incidental service, storage, mechanical equipment rooms, heating/cooling systems and similar uses, and other areas not intended for use by the general public. Where these areas are not yet defined, leasable floor area shall be considered to be eighty-five percent (85%) of the gross floor area.

- b. **Bench Seating.** In calculating bench seating for places of assembly, each twenty-four (24) inches of benches, pews or other such seating, shall be counted as one (1) seat.

CITY OF FENTON ZONING ORDINANCE

- c. **Employees.** Where the number of spaces required is based on the number of employees, calculations shall be based upon the maximum number of employees likely to be on the premises at any one time and may include overlap of employees during shift changes.
- d. **Fractional Spaces.** When units of measurements determining the number of required parking or loading spaces result in a fractional space, any fraction shall be counted as one (1) additional space.

Sec. 19.04 Parking Space Numerical Requirements

The minimum number of off-street parking spaces shall be determined by the type of use in accordance with the following schedule:

Parking Space Numerical Requirements	
Residential	
Mobile or Manufactured Homes in a Mobile Home or Manufactured Housing Park	2.0 spaces per dwelling unit plus 5.0 additional spaces for any office or clubhouse facility, plus 1 visitor space for every 3 homes
Multiple-family Dwellings	1.5 spaces per each efficiency or one-bedroom dwelling unit, 2.0 spaces per each unit with two bedrooms, 2.5 spaces per each unit with three or more bedrooms, plus 5.0 additional spaces for any office, plus 1.0 space per 200 sq. ft. of GFA of any clubhouse facility, plus visitor off-street parking equal to at least 20% of the total spaces required
Single- & two-family dwellings	2.0 spaces per dwelling unit
Housing for the Elderly	
Congregate, Assisted Living or Interim Care Housing	1.0 space per each room or three beds, whichever is less,
Dependent Housing Facilities including convalescent homes, nursing homes, rest homes, etc.	1.0 space per each four beds or two rooms, whichever is less,
Senior Apartments	1.0 spaces per unit
Institutional/Public	
Adult & Child Care Facilities	1.0 space per 400 sq. ft. of GFA, plus 1.0 space per employee, plus adequate drop-off area
Auditoriums, Assembly Halls, Stadiums and Sports Arenas with Fixed Seating	1.0 space per each three seats or six lineal feet of bleachers
Churches, Temples & Other Places of Worship or Public Assembly	1.0 spaces per each three seats or six feet of pews in the main unit of worship, plus required spaces for any accessory uses such as a school, child care center, recreation facilities, etc.
Community Centers Including Senior Centers, Cultural Centers & Teen Centers	1.0 space per each 250 sq. ft. of GFA, or 1.0 space per every four persons of capacity authorized by the Uniform Building Code, plus 1.0 space per employee, whichever is greater
Group Day-care Homes, Adult Foster Care Group Homes, & Adult Congregate Care Facilities	1.0 space per four residents, plus 1.0 space per employee, plus adequate drop-off spaces
Hospitals, Outpatient Service Centers, Urgent Care Centers, Emergency Medical Stations & Similar Uses	1.0 space per 175 sq. ft. of GFA plus 1.0 space per employee
Lodge & Union Halls; Fraternal Orders; Private & Civic Clubs & Similar Uses	1.0 space per every three persons of capacity authorized by the Uniform Building Code
Municipal Office Buildings	1.0 space per 250 sq. ft. of GFA

CITY OF FENTON ZONING ORDINANCE

Parking Space Numerical Requirements	
Post offices, Public Libraries, Museums	1.0 space per 200 sq. ft. of GFA (available for public use) plus spaces for employees and delivery vehicles
Public Utility Use	1.0 space per employee
Schools, Elementary & Middle Schools	2.0 spaces per classroom plus 2.0 drop-off spaces per classroom plus spaces required for any assembly hall, auditorium, and/or outdoor arena or athletic fields
Schools, High Schools, Colleges, Business & Vocational Schools, & Technical Training Facilities	2.0 spaces per classroom plus 15.0 student spaces per classroom plus parking required for any assembly hall, auditorium, or outdoor arena
Office	
Banks, Credit Unions, Savings & Loans	1.0 space per 200 sq. ft. of GFA, plus 2.0 spaces per each 24-hour teller, plus 4.0 stacking spaces for the first drive-through window and 2.0 stacking spaces for each additional drive-through lane
Business Offices & Professional Services	1.0 space per 300 sq. ft. of GFA
Medical and Dental Clinic/Offices (where such use comprises at least 50% of the building or site)	1.0 space per 150 sq. ft. of GFA
Veterinary Offices, Clinics or Hospitals	1.0 space per 250 sq. ft. of GFA.
Commercial	
Animal Grooming Establishments	1.0 space per 300 sq. ft. of GFA plus 1.0 space per employee
Appliance Stores	1.0 space per 250 sq. ft. of GFA
Automobile Gasoline Stations	1.0 spaces per each pump island and service bay (bay can be included as a space), plus 1.0 space per employee, plus plus 1.0 space for each 500 sq. ft. of GFA devoted to sales of automotive goods, plus required spaces for any convenience store (mini-mart), restaurant or auto wash
Automobile & Vehicle Service Centers & Auto Repair Establishments	3.0 spaces for each service bay (bay can be included as a space), plus 1.0 space per employee, plus 1.0 space for each tow truck. plus 1.0 stacking space per bay
Automobile & Vehicle Dealerships Including Recreational Vehicles, Boats, Motorcycles, & Mobile Homes	1.0 space per 400 sq. ft. of GFA of interior sales space plus 1.0 space per 600 sq. ft. of GFA of exterior display, plus 3.0 spaces per each service bay (bay can be included as a space)
Automobile Washes (Automatic)	2.0 spaces, plus 1.0 space per employee, plus 12.0 stacking spaces per bay for free-standing washes, 6.0 stacking spaces when accessory to a gas station
Automobile Washes (Self-service or Coin Operated)	2.0 spaces per bay for drying, plus 3.0 stacking spaces per wash bay
Bars, Taverns, Lounges, and Brewpubs (majority of sales consist of alcoholic beverages)	1.0 space per 75 sq. ft. of GFA
Barber Shops, Beauty Salons, and Tanning Facilities	1.0 space per 175 sq. ft. of GFA or 2.5 spaces per each barber or beautician's chair/station, whichever is greater
Bookstores	1.0 space per 200 sq. ft. of GFA
Business & Personal Service Establishments	1.0 space per 300 sq. ft. of GFA plus 1.0 space per employee

CITY OF FENTON ZONING ORDINANCE

Parking Space Numerical Requirements	
Conference, Meeting or Banquet Rooms; Exhibit Halls & Similar Uses	1.0 space per every two persons of capacity authorized by the Uniform Building Code
Convenience Stores (Mini-marts), with or Without Gasoline Service	1.0 space per 250 sq. ft. of GFA, plus spaces required for automobile gasoline stations plus 2.0 stacking spaces
Discount Stores & Department Stores	1.0 space per 200 sq.ft. of GFA
Dry Cleaners	1.0 space per 500 sq. ft. of GFA plus 2.0 stacking spaces per drop off station
Equipment Repair Establishments	1.0 space per 800 sq. ft. of GFA
Funeral Homes & Mortuary Establishments	1.0 space per 50 sq. ft. of GFA of service parlors, chapels and reception area, plus 1.0 space per each funeral vehicle stored on the premises
Furniture, Carpet & Flooring Stores	1.0 space per 500 sq. ft. of GFA
General Retail & Service Uses Not Otherwise Specified	1.0 space per 200 sq. ft. of GFA
Grocery Store & Retail Food Establishments	1.0 space per 250 sq. ft. of GFA
Hardware, Paint & Home Improvement Stores	1.0 space per 200 sq. ft. of GFA including outdoor sales space
Kennels, Commercial	1.0 space per 400 sq. ft. of GFA, plus 1.0 space per employee
Laundromats	1.0 space per each two (2) washing machines, plus 2.0 spaces for employees
Marinas	1.0 space per each boat slip during boating season, plus 1.0 space per each five (5) dry-docked boats during the winter season, plus additional access and maneuvering space as determined necessary by the Planning Commission, plus year-round parking spaces as required for other uses such as clubhouse, restaurant or retail store
Mini or Self-storage Warehouses	minimum of 6.0 spaces
Motel, Hotel, Bed & Breakfast Inn, Boarding Houses & Similar Uses	1.0 space per guest room, plus 1.0 space per employee, plus 75% of required spaces for restaurants, conference rooms, banquet halls and other uses
Open Air Businesses including Nurseries, Garden Centers & Other Outdoor Display, Sales, & Storage Uses	1.0 space per 500 sq. ft. of GFA of outdoor display, sales and storage area, plus 1.0 space per 200 sq. ft. of GFA of indoor space, plus 1.0 space per employee
Pharmacies	1.0 space per 200 sq. ft. of GFA plus 3.0 stacking spaces for any drive-through windows
Restaurants, Standard, with Liquor License	1.0 space per 60 sq. ft. of GFA, or 0.6 spaces per seat, whichever is greater, plus spaces required for any banquet or meeting rooms
Restaurants, (Standard, Without Liquor License)	1.0 space per 70 sq. ft. of GFA or 0.5 spaces per seat, whichever is greater, plus spaces required for any banquet or meeting rooms, plus up to 3.0 longer spaces designated for recreational vehicles and semi trucks (as required by the Building Official/Zoning Administrator for sites in proximity to U.S. 23)
Restaurants, Fast Food with Drive-through Window, Including Coffee Shops, Cafes, Delicatessens, etc.	1.0 space per 80 sq. ft. of GFA, plus plus 10.0 stacking spaces, plus up to 2.0 longer spaces designated for recreational vehicles and semi trucks (as required by the Building Official/Zoning Administrator for sites in proximity to U.S. 23)

CITY OF FENTON ZONING ORDINANCE

Parking Space Numerical Requirements	
Restaurants, Fast Food Without Drive-through Window	1.0 space per 80 sq. ft. of GFA or 0.5 spaces per seat, whichever is greater, plus up to 2.0 longer spaces designated for recreational vehicles and semi trucks (as determined by the Building Official/Zoning Administrator for sites in proximity to U.S. 23)
Restaurants, Drive-in	1.0 space per drive-in station, plus 1.0 space per employee
Restaurant Carry-out & Open Front Window, with fewer than 6 Tables and/or Booths	6.0 spaces plus 1.0 space per employee
Showroom of a Plumber, Decorator or Similar Trade	1.0 space per 800 sq. ft. of GFA
Shopping Centers with less than 100,000 Sq. Ft. Gross Leasable Floor Area	1.0 space per 225 sq. ft. of GFA, plus spaces required for any grocery store, bookstore or restaurant, if included
Shopping Centers with 100,000 Sq. Ft. or More Gross Leasable Floor Area	1.0 space per 250 sq. ft. of GFA, plus spaces required for any grocery store, bookstore, or restaurant, if included
Studios for Art, Photography, Music, Dance & Similar Uses	1.0 space per 300 sq. ft. of GFA plus 1.0 space per employee
Video Rental Establishments	1.0 space per 200 sq. ft. of GFA, with a minimum of 8.0 spaces provided
Wholesale Establishments & Warehouse Clubs	1.0 space per 500 sq. ft. of GFA
Recreation/Entertainment	
Arcades	2.0 spaces per machine plus 1.0 space per employee
Baseball & Softball Fields	25.0 spaces per field
Batting Cages	3.0 spaces per cage
Boat Marinas	1.5 spaces per boat berth, plus required spaces for winter boat storage and other uses
Bowling Centers	3.0 spaces per lane, plus 0.5 spaces per seat in spaces designated for any lounge or dining area
Golf Course Driving Ranges	1.0 space per tee
Golf Courses, Miniature & Par Three	2.0 spaces per each course hole, plus 1.0 space per employee
Golf Courses	6.0 spaces per each course hole, plus 1.0 space per employee, plus required spaces for restaurants, banquet rooms, pro shop, offices, and other uses
Health Clubs & Fitness Centers	1.0 space per 250 sq. ft. of GFA, plus required spaces for swimming pools, courts, restaurants and other uses
Ice/roller Skating Rinks	1.0 space per 170 sq. ft. of GFA, or 1.0 space for each 6.0 seats or feet of bench, whichever is greater, plus 50% of parking required for restaurants, pro shops and other uses
Pool & Billiard Halls	1.0 space per 70 sq. ft. of GFA or 1.0 space per every three persons of capacity authorized by the Uniform Building Code
Recreation Centers (Indoor) Commercial, Not Already Specified	1.0 space per 1,000 sq. ft. of GFA, plus required spaces for restaurants, banquet rooms, offices, sales area, and other uses
Recreation Centers (Outdoor) Public or Commercial	1.0 space per 200 sq. ft. of GFA
Soccer and Football Fields	30.0 spaces per field

CITY OF FENTON ZONING ORDINANCE

Parking Space Numerical Requirements	
Swimming Pools	1.0 space per each three persons of capacity authorized by the BOCA Code
Tennis Courts & Racquetball Centers	1.0 space per 1,000 sq. ft. GFA or 6.0 spaces per court, whichever is greater, plus 50% of required spaces for restaurants, banquet rooms, offices, sales area, & other uses
Theaters, Cinemas	1.0 space per each three seats plus 1.0 space per two employees
Industrial	
Light Industrial, Manufacturing, Testing Labs, Research, Design & Development Centers	1.0 space per 700 sq. ft. GFA, or 1.2 spaces per employee, whichever is greater, plus 1.0 space for each corporate vehicle, plus spaces required for any office or sales area
Warehousing & Wholesale Establishments (Non-retail)	1.0 space per each 1,500 sq. ft. GFA, or 1.0 space per employee, whichever is greater; plus 1.0 space for each corporate vehicle plus spaces required for any office/sales area

Sec. 19.05 Barrier-Free Parking Requirements

Each parking lot that serves a building or use, with the exception of single and two-family dwelling units, shall provide barrier free spaces in compliance with the State Building Code.

Sec. 19.06 Off-street Parking Space Design and Setback Requirements

Where required, off-street parking facilities containing more than five (5) parking spaces shall be designed, constructed, and maintained according to the following standards and regulations:

a. Ingress and Egress

1. Adequate ingress and egress to the parking facility shall be provided by clearly defined driveways in accordance with *ARTICLE 20 ACCESS MANAGEMENT AND DRIVEWAY STANDARDS*.
2. All spaces shall be provided adequate access by means of maneuvering lanes.
3. Spaces backing directly onto a street use of the street for maneuvering between parking rows shall be prohibited.
4. Access to off-street parking which serves a nonresidential use shall not be permitted across land that is zoned or used for residential purposes.

b. Surfacing, Drainage, and Grading

1. Grading, surfacing, and drainage plans shall comply with city engineering specifications and subject to the review and approval of the city engineer. All driveways, parking lots, access lanes and other vehicle maneuvering areas shall be hard-surfaced with concrete or plant-mixed bituminous material in accordance with specifications of the City.
2. Off-street parking areas, access lanes, and driveways shall be graded and drained so as to dispose of surface waters. Surface water shall not be permitted to drain onto adjoining property, unless in accordance with an approved drainage plan.
3. All driveways, parking lots, and loading-unloading areas shall not be less than one percent (1%) and not exceed a grade differentiation of four percent (4%).

c. **Curbs.** A raised or rolled concrete curb a least six (6) inches in height shall be installed with the construction of all driveways, parking lots, access lanes and other vehicle maneuvering areas to prevent motor vehicle conflicts with abutting landscape areas, sidewalks, streets, buildings or adjoining property.

d. **Parking Lot Setbacks**

1. **From Street Rights-of-Way.** In accordance with *Section 19.02 paragraph b. Location*, the Planning Commission may determine that parking lots may be appropriate in the front yard. If such determination has been made, parking lots, including drives and maneuvering aisles but excluding driveways, must be set back a minimum of twenty (20) feet from any adjacent street right-of-way line in all zoning districts except the CBD. Required parking lot setback areas shall be landscaped according to the standards of *ARTICLE 21 LANDSCAPE STANDARDS AND TREE REPLACEMENT*.
2. **From Non-Residential Districts.** Parking lots shall have a minimum setback of ten (10) feet from any nonresidential property line that is not a street right-of-way line. This requirement may be waived by the Planning Commission where a shared access driveway, connected parking lots, frontage road, or rear service drive, designed in accordance with *ARTICLE 20 ACCESS MANAGEMENT AND DRIVEWAY STANDARDS*, is provided.
3. **From Residential Districts.** Parking lots shall have a minimum rear and side yard setback of fifty (50) feet from any single-family residential zoning district and twenty (20) feet from any multiple-family residential zoning district. This setback area shall include either berming, landscaping and/or a wall to screen headlights, designed according to the standards of *ARTICLE 21 LANDSCAPE STANDARDS AND TREE REPLACEMENT*

e. **Dimensions.** All spaces shall be designed and marked with dimensions described below and shown in *Figure 19.1 Off-Street Parking Design Standards*:

Dimensions			
Parking Pattern	Parking Space Dimension	2-Way Aisle Width	1-Way Aisle Width
80-90 degree	9 feet X 18 feet	26 feet	not permitted
60-75 degree	9 feet X 21 feet	24 feet	18 -20 feet
45-55 degree	9 feet X 21 feet	24 feet	15 feet
parallel parking	9 feet X 25 feet with 3-foot area striped for "no parking" between each two (2) spaces	22 feet	15 feet

f. **Parking Lot Marking.** All parking spaces must be marked with double (or loop) stripes three (3) to four (4) inches wide and spaced not less than eighteen (18) inches apart and no greater than twenty-four (24) inches apart (see *Figure 19.1 Off-Street Parking Design Standards*).

Figure 19.1 Off Street Parking Design Standards

For required barrier-free parking requirements refer to the State Building Code

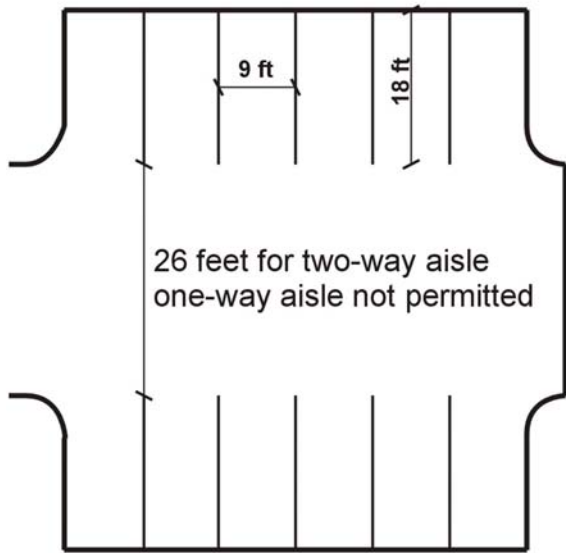

80-90 Degree Pattern

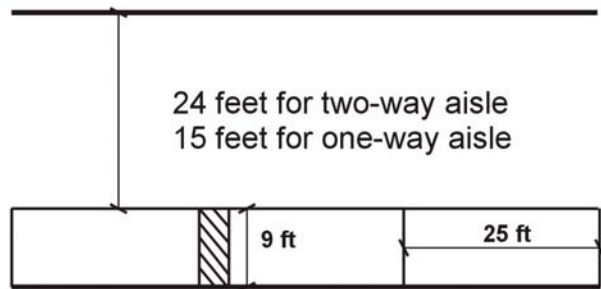

Parallel Pattern

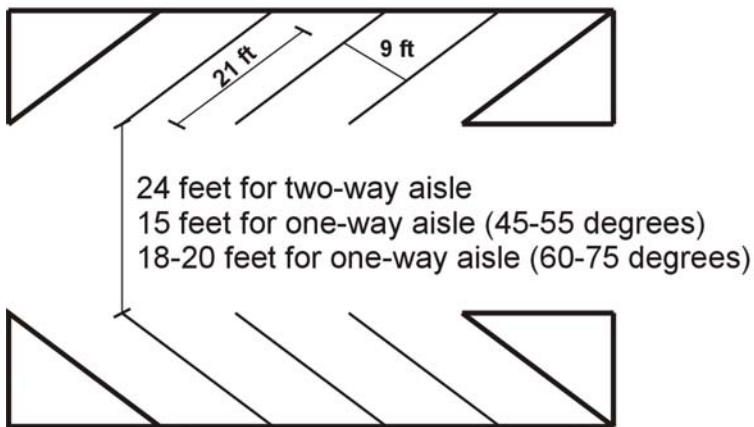

45-75 Degree Pattern

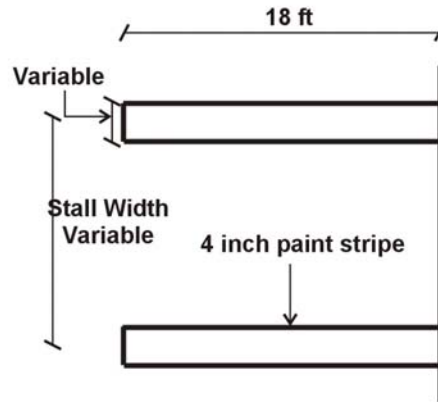

Double or Loop Striping Pattern

Sec. 19.07 Parking Lot Construction and Maintenance

- a. Plans and specifications for parking and loading areas shall be submitted to the Building Official/Zoning Administrator prior to the issuance of a building permit. These plans shall at a minimum :
 - 1. Show existing and proposed grades.
 - 2. Be designed to ensure that stormwater runoff shall be accommodated on-site through approved drainage facilities, including catch basins, runoff calculations, pipe sizes and connections to existing drainage structures.
 - 3. Provide specifications on surface and base materials to be used for construction.
- b. Required parking lots shall be installed and completed within six (6) months of receipt of a building permit and before issuance of an occupancy permit. The Building Official/Zoning Administrator may grant a single extension for an additional six (6) months in the event of adverse weather conditions or unusual delays beyond the control of the property owner.
- c. All parking areas shall be maintained free of dust, trash, and debris. Surfacing, curbing, lighting fixtures, signs, and related appurtenances shall be maintained in good condition.
- d. The visibility of pavement markings delineating parking spaces and directional control shall be maintained.
- e. All off-street parking and loading facilities required by this Article shall be maintained free of accumulated snow or standing water which prevent full use and occupancy of such facilities, except for temporary periods of no more than five (5) days in the event of heavy rainfall or snowfall.

Sec. 19.08 Off-Street Loading and Unloading Requirements

- a. **General Applicability.** On-premises space for standing, loading and unloading vehicles shall be provided for each use involving the receipt or distribution of goods. Compliance with the loading space regulations set forth herein shall be required in order to avoid interference with the public use of streets, alleys, parking areas, driveways, sidewalks, and other public areas.
- b. **Change in Use and Intensity.** Whenever use of a building, structure, or lot is changed, loading space shall be provided as required by this article for the new use, regardless of any variance which may have been in effect prior to change of use.
- c. **Location**
 - 1. Loading/unloading areas and docks shall be prohibited in the front yard or on any building side facing and directly visible from a public street.
 - 2. Loading/unloading operations shall not interfere with traffic on public streets or off-street parking.
 - 3. The vehicular path and turning radii to the loading area must be shown on the site plan to verify truck maneuverability for the largest truck intended to serve the use.
- d. **Size.** The size of all required loading/unloading spaces shall be at least ten (10) feet by fifty (50) feet or five hundred (500) square feet in area for office uses and at least ten (10) feet by seventy (70) feet or seven hundred (700) square feet in area for commercial and industrial uses, with a clearance of at least fourteen (14) feet in height.

e. **Surfacing and Drainage**

1. Loading areas shall be hard-surfaced with concrete or plant-mixed bituminous material.
2. Loading areas shall be graded and drained so as to dispose of surface waters.
3. Surface water shall not be permitted to drain onto adjoining property, unless in accordance with an approved drainage plan.
4. Grading, surfacing, and drainage plans shall be subject to review and approval by the engineer.

f. **Storage and Repair.** The storage of merchandise, sale of motor vehicles, storage of inoperable vehicles, or repair of vehicles is prohibited in required loading space.

g. **Central Loading.** Central loading facilities may be substituted for individual loading spaces serving businesses on separate lots provided that all of the following conditions are fulfilled:

1. Each business served shall have direct access to the central loading area without crossing streets or alleys.
2. Total loading space provided shall meet the minimum requirements specified herein, in consideration of total floor area of all businesses served by the central loading space.
3. No building served shall be more than three hundred (300) feet from the central loading area.

h. The minimum number of loading spaces shall be provided in accordance with the following table. The Planning Commission may modify these requirements upon making the determination that another standard would be more appropriate because of the number or type of deliveries experienced by a particular business or use.

Central Loading	
Institutional, Commercial and Office Uses	
Up to 5,000 sq. ft. GFA	1.0 space.
5,001-60,000 sq. ft. GFA	1.0 space, plus 1.0 space per each 20,000 sq. ft. GFA or fraction thereof
60,001 sq. ft. GFA and over	3.0 spaces, plus 1.0 space per each 50,000 sq. ft. GFA or fraction thereof
Industrial Uses	
Up to 1,400 sq. ft. GFA	0
1,401-20,000 sq. ft. GFA	1.0 space
20,001-100,000 sq. ft. GFA	1.0 space, plus 1.0 space per each 20,000 sq. ft. GFA in excess of 20,000 sq. ft. or fraction thereof
100,001 sq. ft. GFA and over	5.0 spaces

i. **Screening.** When required off-street loading in a nonresidential district is visible from public view or abuts a residential district, the off-street loading shall be screened by a solid, ornamental masonry wall at least six (6) feet in height above the grade elevation at the residential district line, in addition to the landscape requirements of *ARTICLE 21 LANDSCAPE STANDARDS AND TREE REPLACEMENT*.

1. **Calculation.** Required loading areas shall not be included in calculations for off-street parking space requirements.
2. **Hours of Operation.** Loading and unloading shall only occur between the hours of 7 a.m. and 11 p.m.